



Cospas-Sarsat Return Link Service Status

Dr. Lisa Mazzuca
NASA Search and Rescue Mission Manager
ICG-13, Xi'an China 2018



Overview of the SAR/Galileo Return Link Service within the Cospas-Sarsat System Architecture

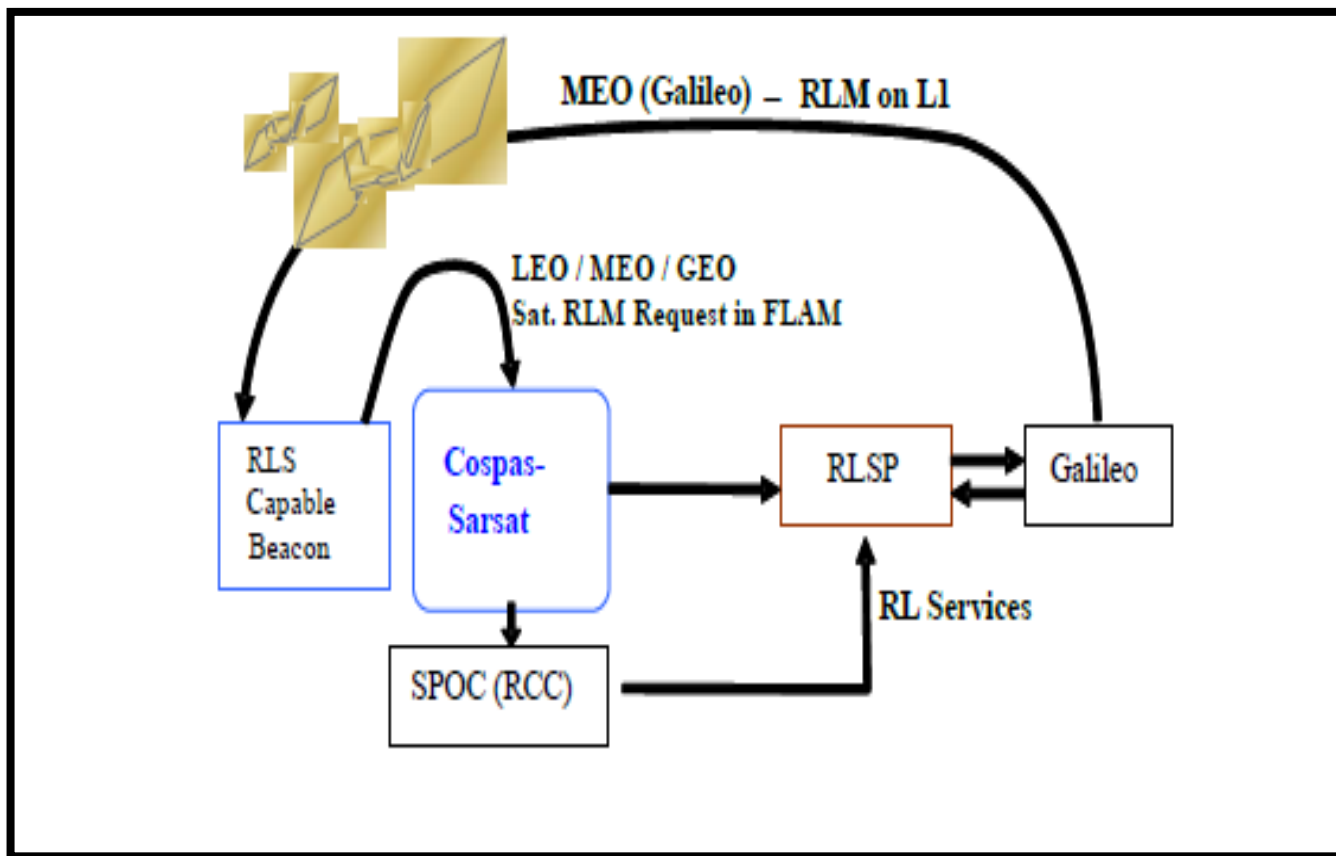

JC-32/8/4 - EC RLS Type 1 Schedule

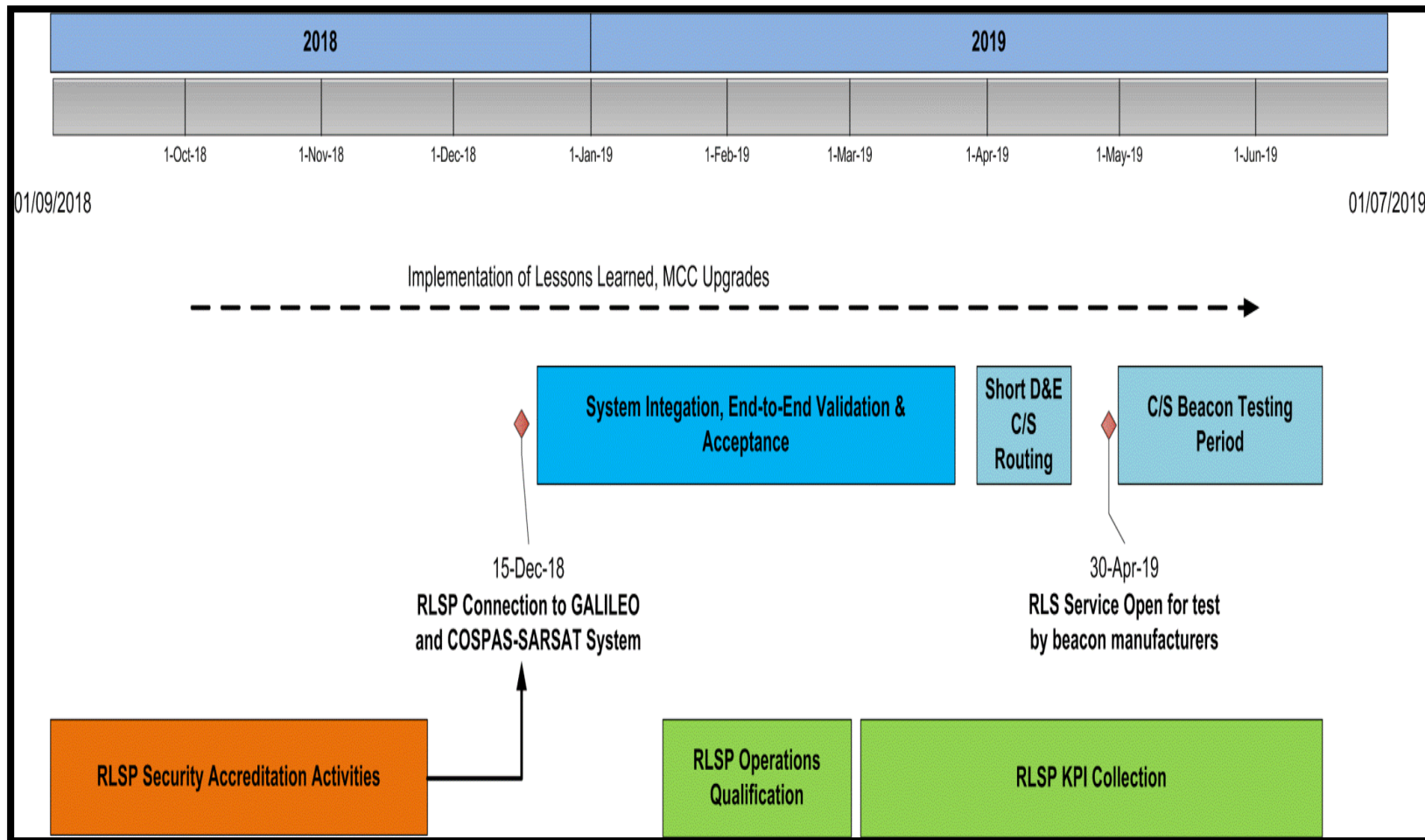

RSLP connection to GALILEO and Cospas-Sarsat System date to move to the right due further C/S discussion and approval to declare RLS availability within C/S system.



- JC-32 Final Report, Section 3.1.5: The Joint Committee noted from document JC-32/3/20 the recommendations that it:
 - Note that new RL Services are being considered by the EC and that these services need to be further developed by interested stakeholders;
 - Recommend the establishment of a new RLS CWG for participants to:
 - be informed of the new services specified in the EUROCAE MASPS for ELTs,
 - be involved in the definition of the potential new RL services and the procedures to implement them,
 - Contribute to the evaluation of the benefits and impacts of new RL Services on the Cospas-Sarsat System, SAR resources and users,
 - Contribute to the development of the required changes in the Cospas-Sarsat System documentation to support the deployment of these new services.

[U.S.A.] RLS Specifications



- U.S.A. proposed that Council make the final decision on whether to accept EC's or propose their own RLS standards that RLSP will have to meet
- Agreed on need to prepare specifications, standards for QMS for front-end of RLS Type-1, under purview of C/S
- Agreed that an action item should be raised inviting EC and others to work by correspondence intersessionally to resolve conflicts by CSC-61 (Jan/Feb 2019)

Backup



- SAR/Galileo will provide a return link service to the beacon through a dedicated facility called the RSLP
- A decision has not been made on the GLONASS or DASS systems on providing RLS
- The Return Link Service can be provided to compatible beacons irrespective of the satellite system (LEO, GEO or MEO) which provided the forward link 406 MHz alert
- 406 MHz beacons with SAR/Galileo RLS capabilities will meet T.001 specifications regarding link message transmission
- Amendments to C/S beacon documents, C/S T.001, C/S T.007, and C/S G.005 are required for development and type approval of 406 MHz beacons with SAR/Galileo RLS capability
- Action performed by beacon still to be decided between two options for RLM:
 - Without acknowledgement of reception by beacon
 - With acknowledgement of reception by beacon