

Gamma-ray astronomy on the way to uncover the mystery of Dark Matter of Universe

A.M. Galper
LPI, NRNU MEPhI, Moscow

COPUOS Vienne, June 2010



Ranges of electromagnetic cosmic radiation

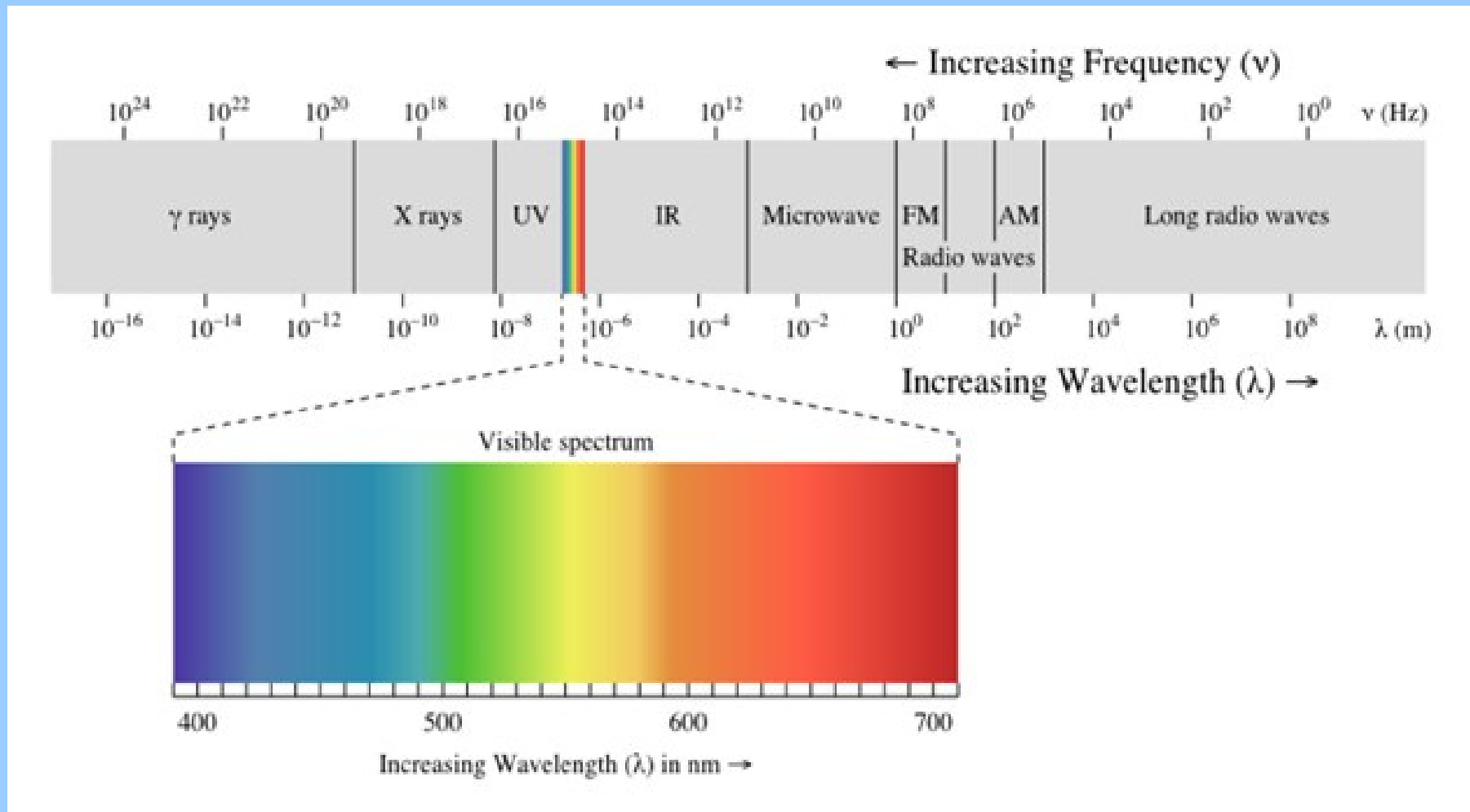

Shock fronts of "Crab Nebula"



Formation of extragalactic jets from black hole accretion disk

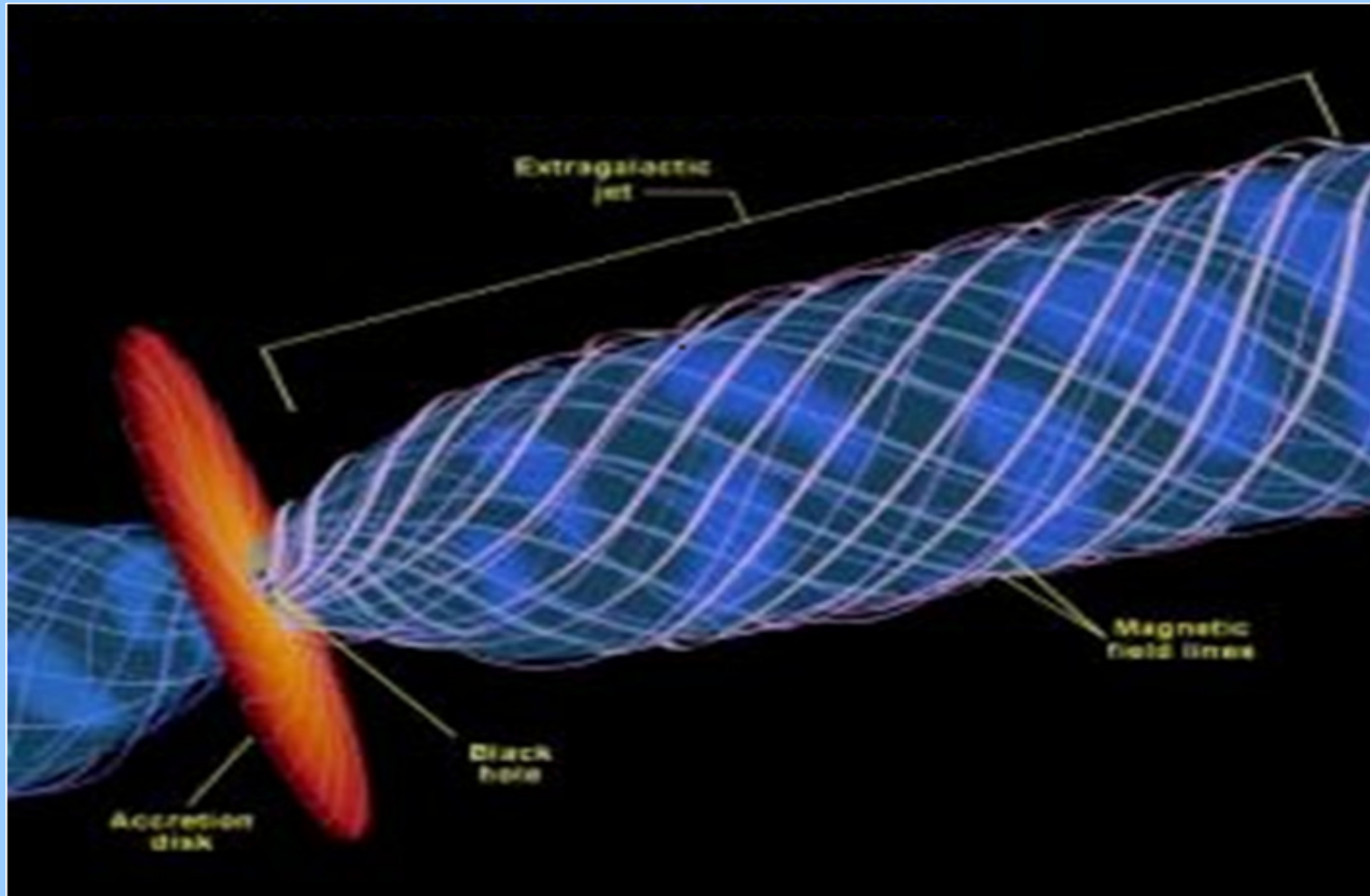

Microquasar model

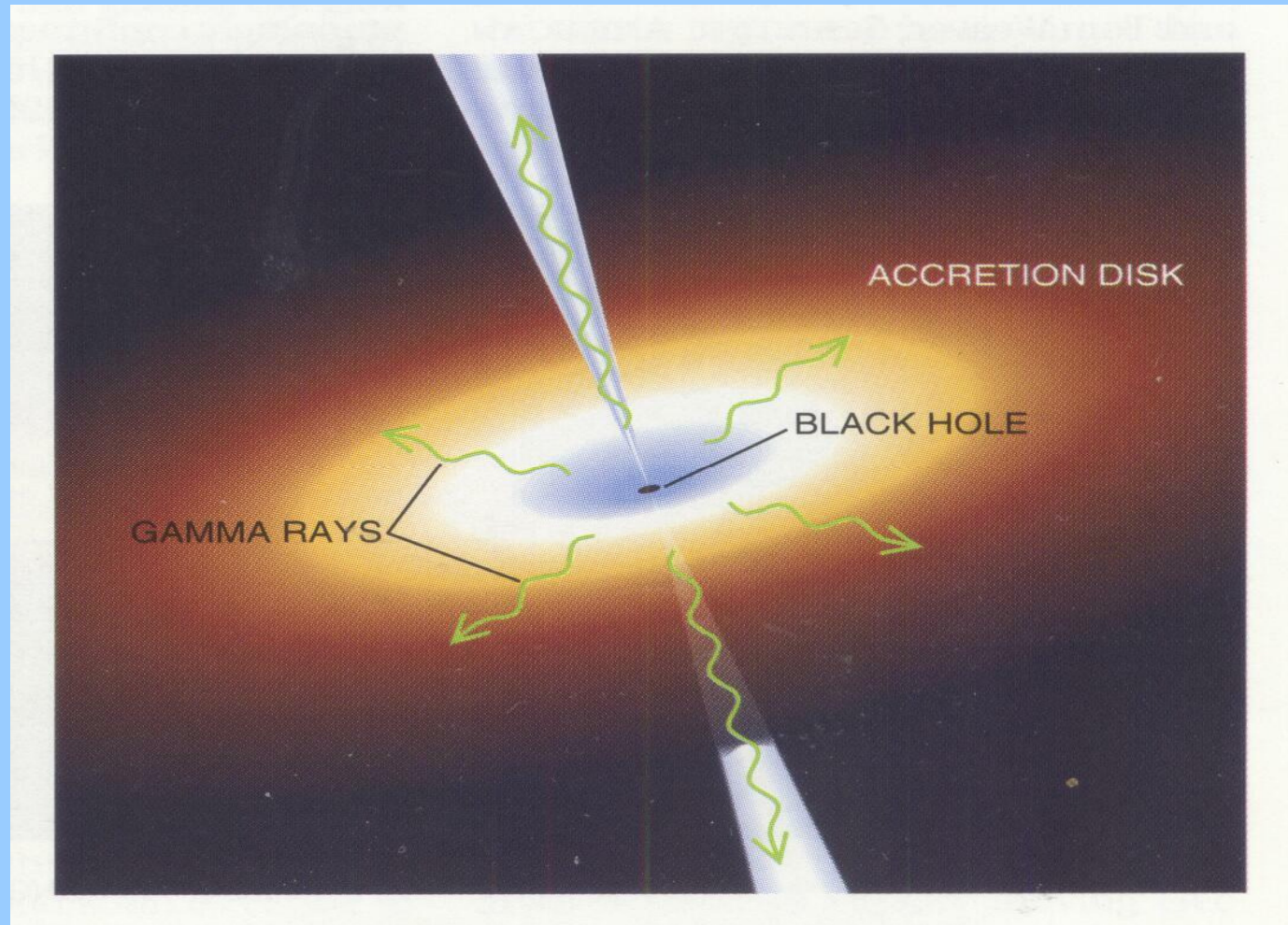

Model of galaxy with an active nucleus

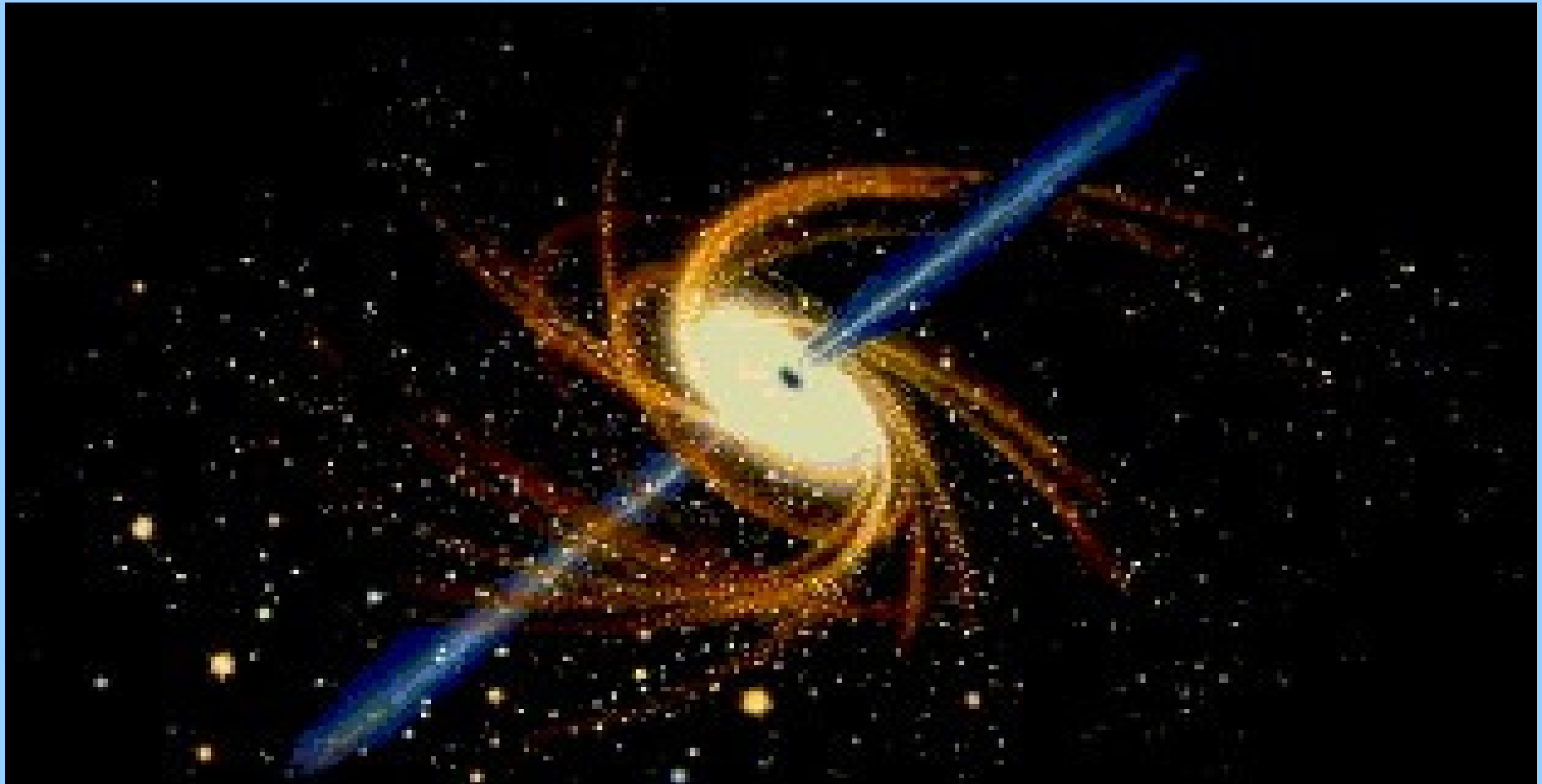

Small-scale DM clumps in the Galactic halo

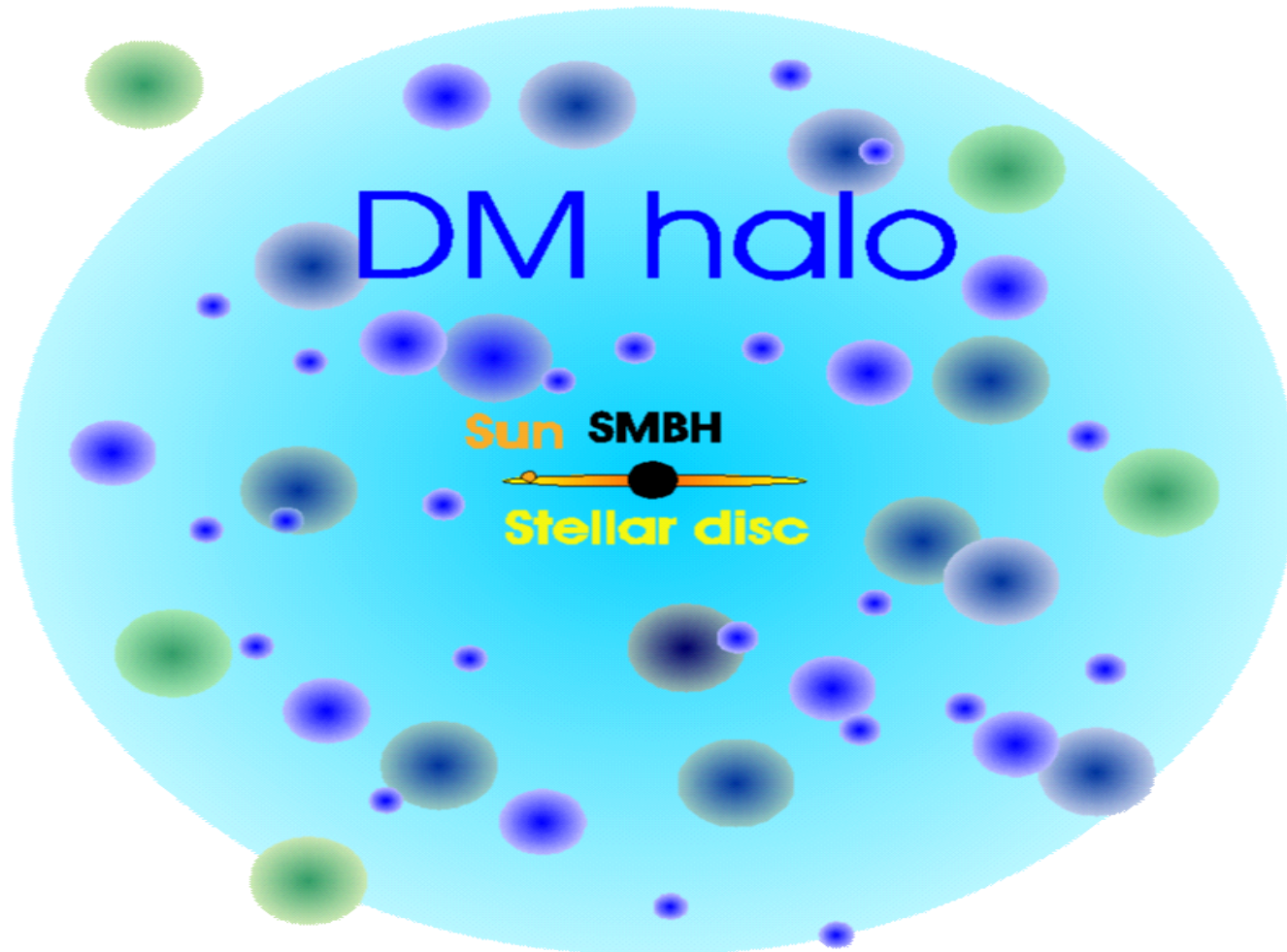

WIMP annihilation

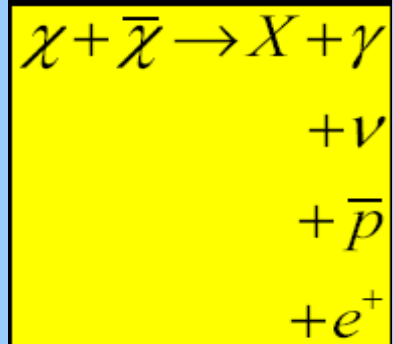
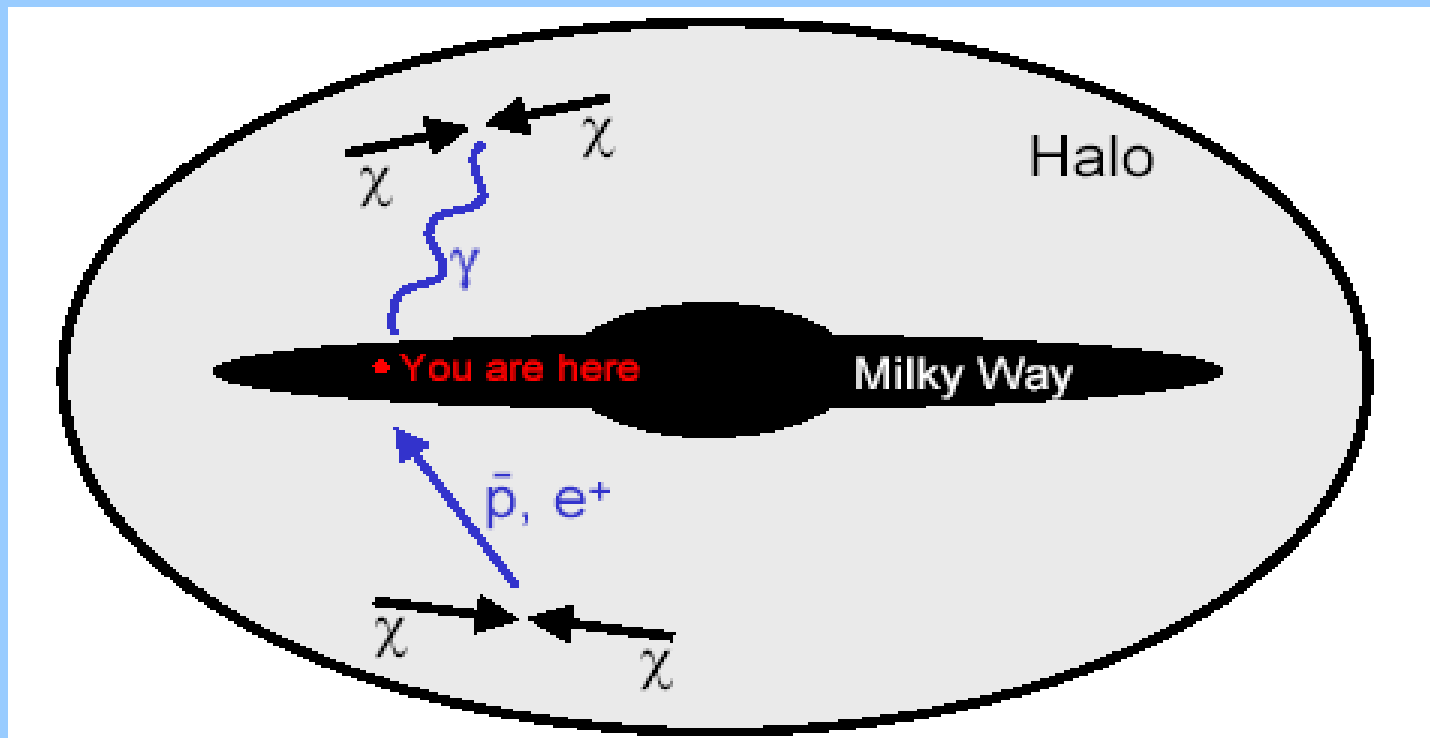

SPACE GAMMA-RAY TELESCOPES

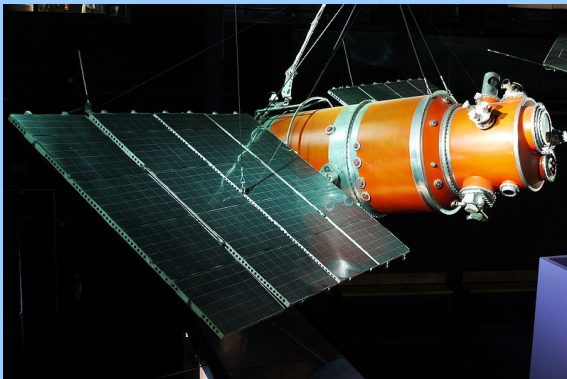

ANNA-3
(Cosmos - 251, 264)

1968, 1969
200 MeV – 1 GeV

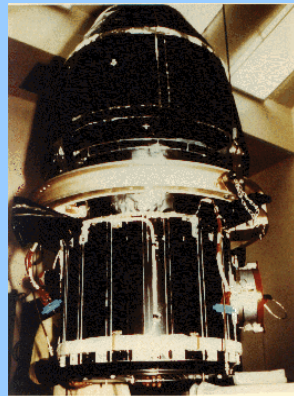

SAS-2

1972 – 1973
20 MeV – 1 GeV

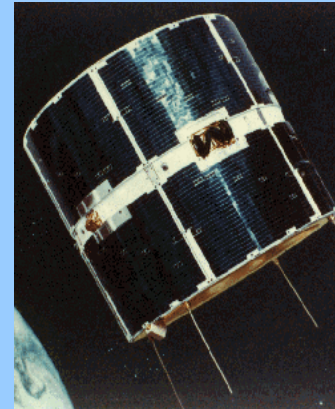

COS-B

1975 – 1982
30 MeV – 5 GeV

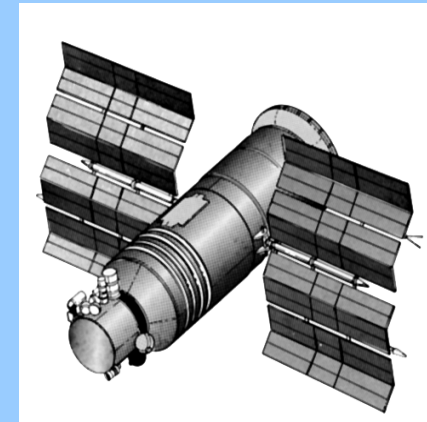

GAMMA-1

1990 – 1992
30 MeV – 5 GeV

SPACE GAMMA-RAY TELESCOPES

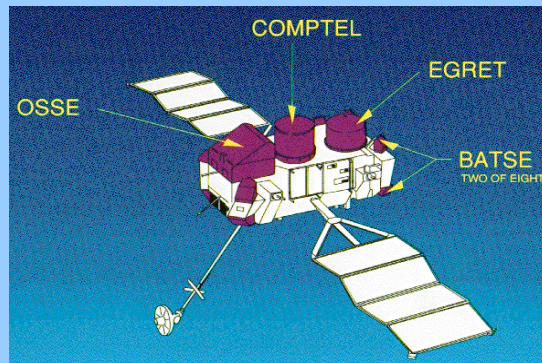

EGRET
(CGRO)
1991- 1998
30 MeV - 30 GeV

AGILE
2007 – 2010
100 MeV – 50 GeV

FERMI
2008
100 MeV – 100 GeV

Map of high-energy gamma-radiation measured by gamma-ray telescope "Fermi/LAT"

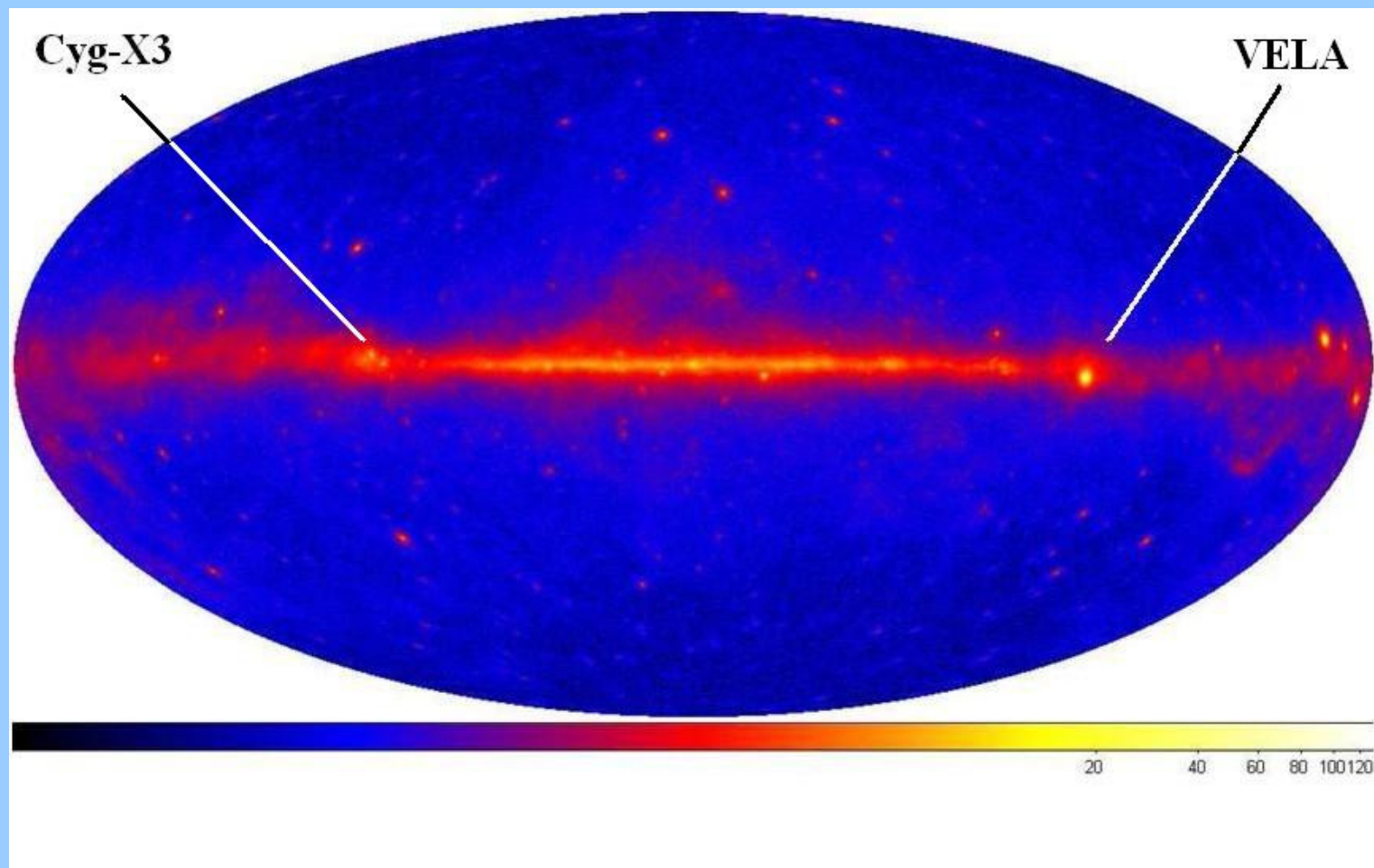



MAIN SCIENTIFIC PROBLEMS OF GAMMA-400 EXPERIMENT

FIELDS OF INVESTIGATIONS

- The investigation of the nature of physical processes in the active astrophysical objects, responsible for the generation of gamma-radiation of ultra-high energy (1 GeV...3 TeV).
- The investigation of the nature and properties of particles, being according some models, the components of dark matter, via the processes of their annihilation and possibly the decay on gamma-quanta and electron-positron pairs.

Angular resolution of the GAMMA-telescope

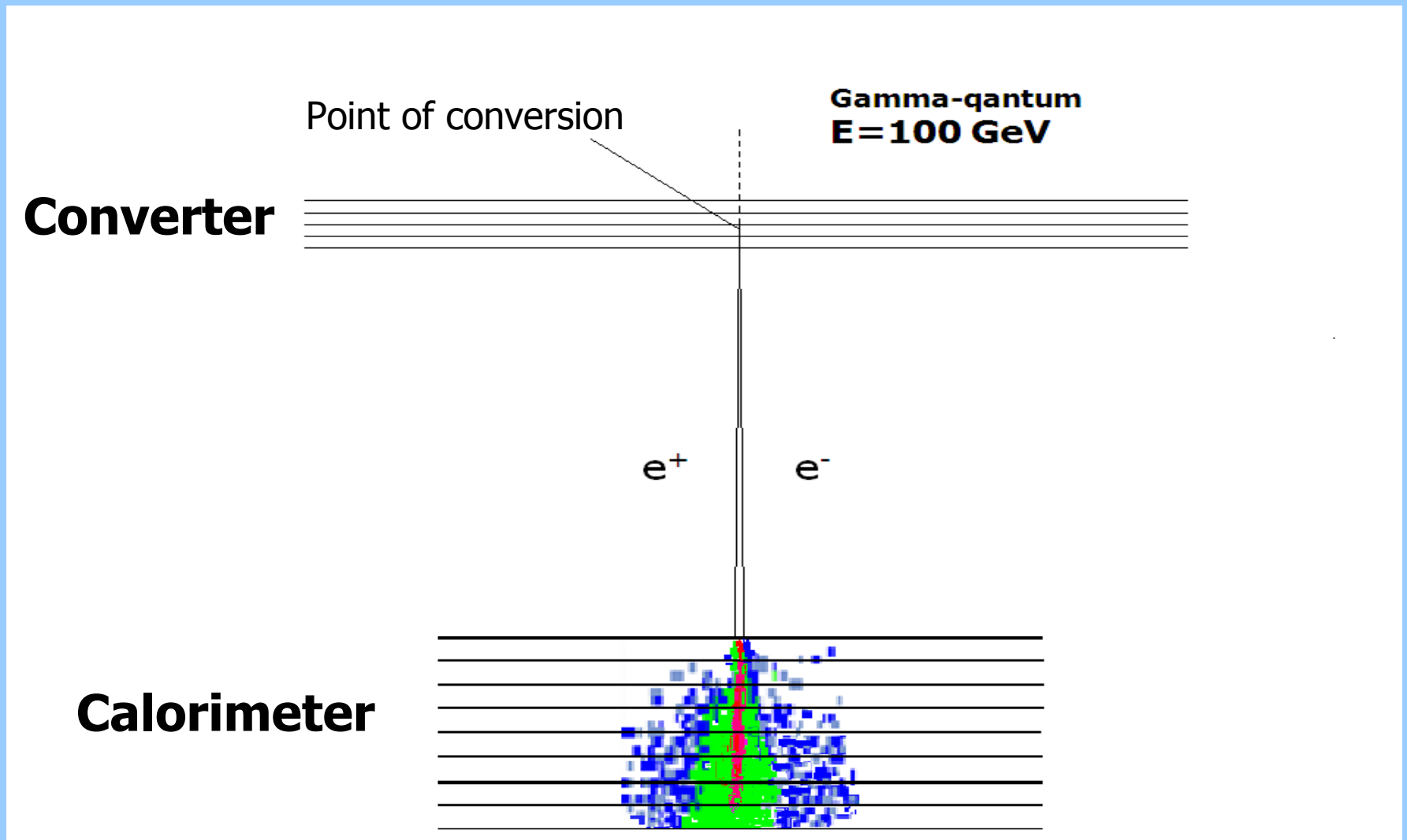

Physical scheme of the GAMMA-400 telescope

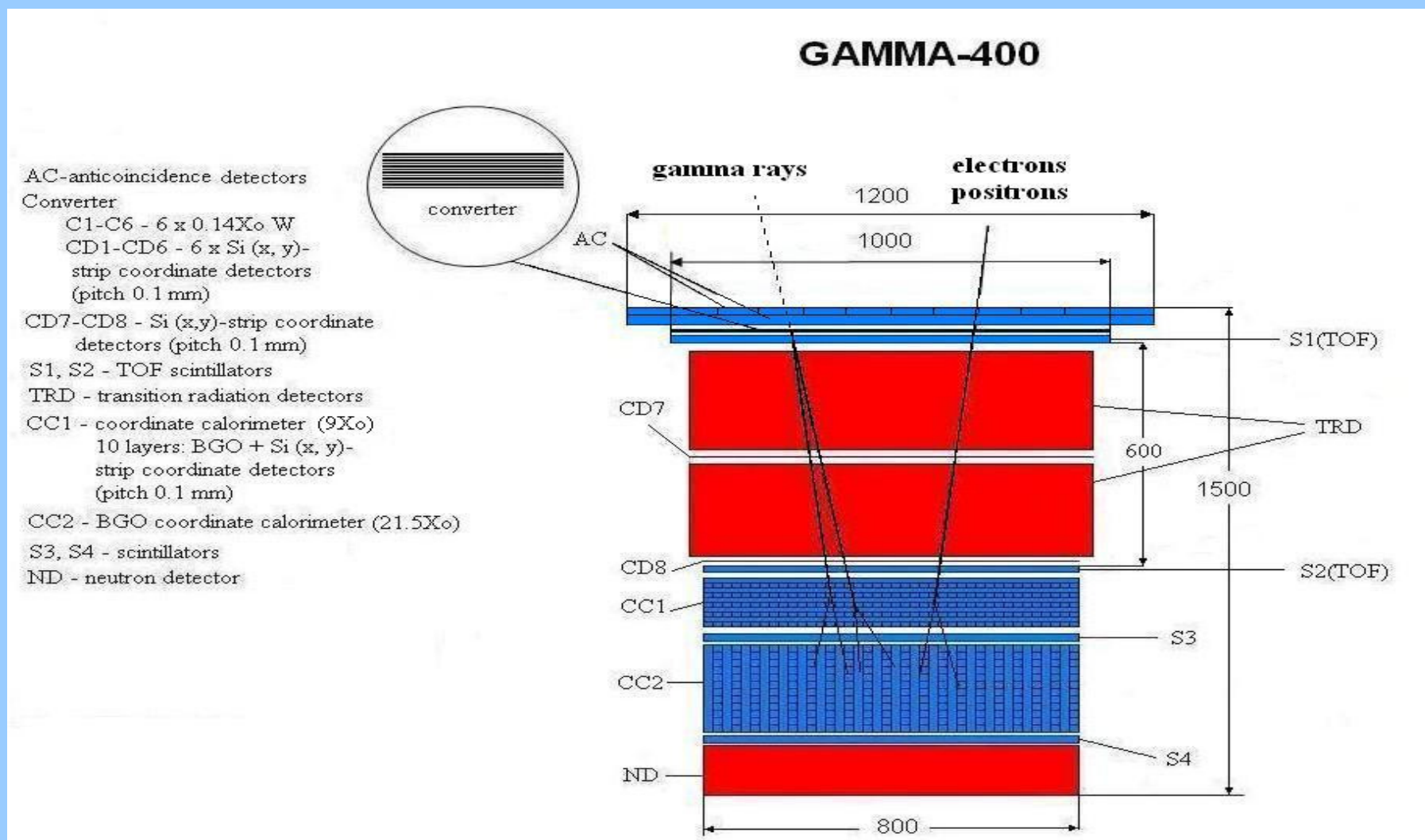

GAMMA-400 telescope on spacecraft "Navigator"

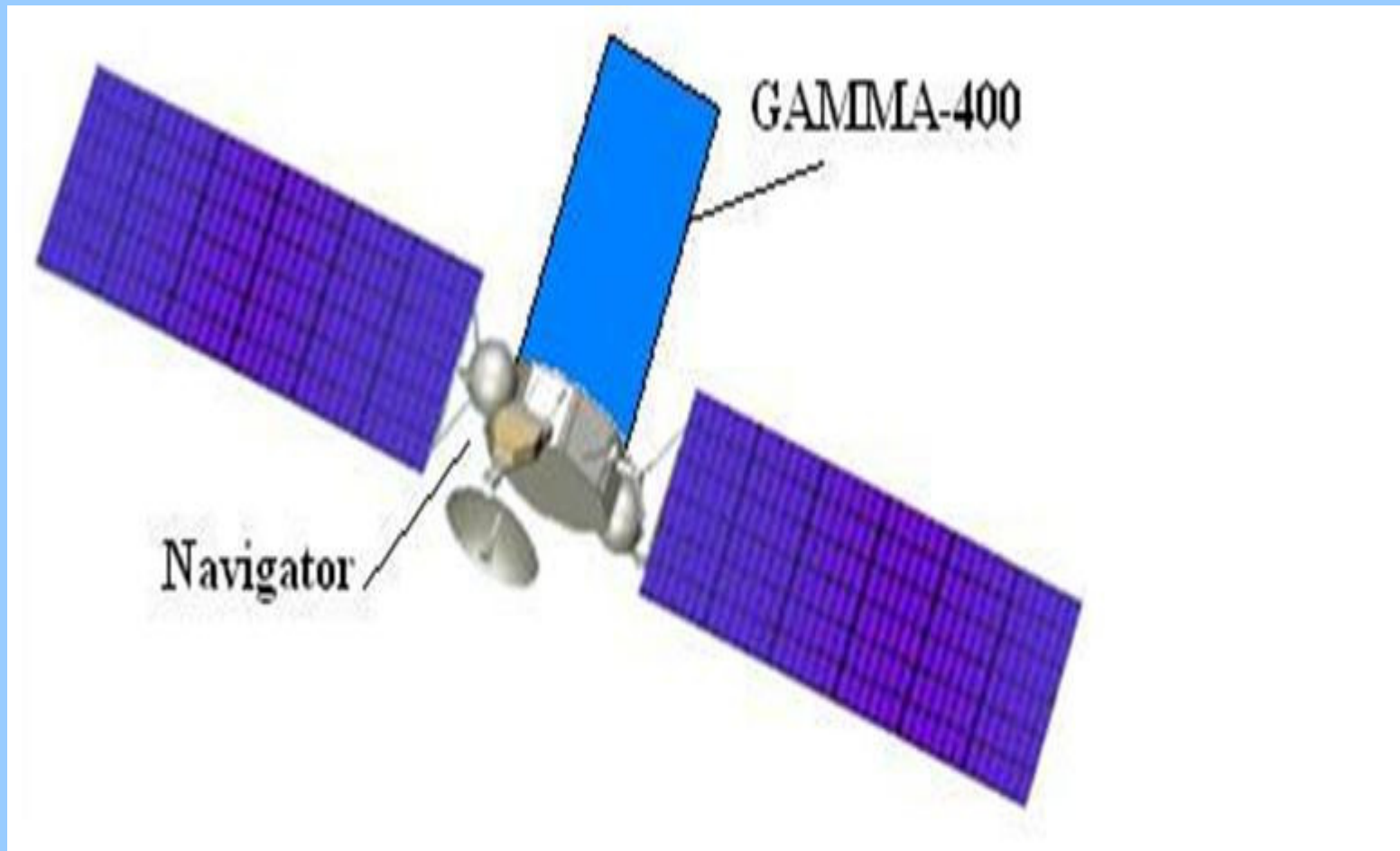

GAMMA-400 flight on spacecraft "Navigator"

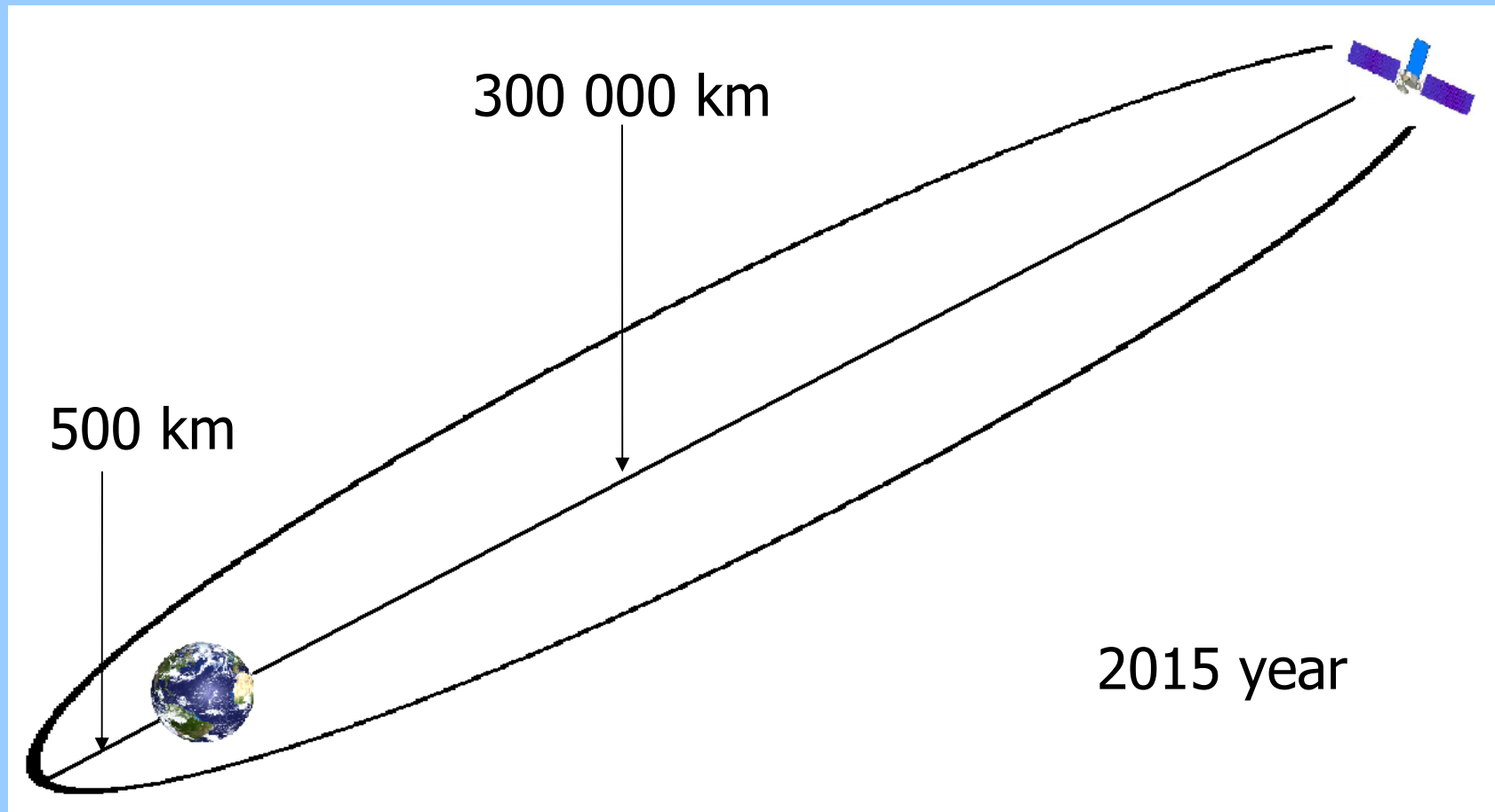



REFERENCES



- [1] *Волобуев С.А., Гальпер А.М., Кириллов-Угрюмов В.Г. и др.* Исследование первичного гамма-излучения с $E > 200$ МэВ на ИСЗ с помощью искровой камеры. // Известия АН СССР. Серия физическая. 1970. Т. 34. №11. С. 2259-2264.
- [2] *Fichtel C., et al.* High-energy gamma-ray results from the second small astronomy satellite. // The Astrophysical Journal. 1975. V. 198. P. 163-182.
- [3] *Bignami G., et al.* The COS-B experiment for gamma-ray astronomy. // Space Science Instrument. 1975. V. 1. P. 245-268.
- [4] *Akimov V., et al.* Determination of the characteristics of the gamma-ray telescope GAMMA-1. // Space Science Reviews. 1988. V. 49. P. 125-138.
- [5] *Kanbach G., et al.* The project EGRET (Energetic Gamma-Ray Experiment Telescope) on NASA's gamma-ray observatory GRO. // Space Science Reviews. 1988. V. 49. P. 69-84.
- [6] *Tavani M., et al.* The AGILE space mission. // Nuclear Instruments and Methods in Physics Research. 2008. V. A588. P. 52-62.
- [7] *Atwood W.B., et al.* The large area telescope on the FERMI gamma-ray space telescope mission. // The Astrophysical Journal. 2009. V. 697. P. 1071-1102.
- [8] *Abdo A.A., et al.* Fermi Large Area Telescope First Source Catalog. // arXiv:1002.2280v1.
- [9] *Abdo A.A., et al.* Fermi observations of TeV-selected active galactic nuclei. // The Astrophysical Journal. 2009. V. 707. P. 1310-1333.
- [10] *Tibaldo L., et al.* Fermi LAT measurements of diffuse gamma-ray emission: results at the first-year milestone. // arXiv:1002.1576v1.
- [11] *Гальпер А.М., Кириллов-Угрюмов В.Г., Лучков Б.И.* Наблюдательная гамма-астрономия. // Успехи Физических Наук. 1974. Т. 112. №3. С. 491-515.
- [12] *Bernardo G.Di., et al.* The High Energy Cosmic Ray Electron Spectrum measured by Fermi Gamma-Ray Space Telescope: some possible interpretations. // arXiv:0912.3887v1.
- [13] *Adriani O., et al.* An anomalous positron abundance in cosmic rays with energies 1.5–100 GeV. // Nature. [2009. V. 458. P. 607-609.
- [14] *Ginzburg V.L., Galper A.M., Fradkin M.I., et al.* Gamma-Ray Telescope "GAMMA-400". Preprint LPI 2009, # 10.

**Thank you
for your
attention!**